

33	VOLANT / HANDWHEEL
32	JOINT OCTOGONAL / OCTOGONAL RING JOINT
31	GARNITURE D'ETANCHEITE / PACKING
30	BRIDE DE FOULOIR / GLAND FLANGE
29	AXE DE COMMANDE / STEM
28	CHAPEAU / BONNET
27	RESSORT / SPRING
25	PLAQUE D'IDENTIFICATION / FIRM PLATE
24	VIS / SCREW
23	ECROU HAUT / HEAVY HEX NUT
22	TIRANT / STUD
21	GARNITURE D'ETANCHEITE / PACKING RING
20	BAGUE ANTI-EXTRUSION / ANTI EXTRUSION RING
19	JOINT TORIQUE / O-RING
15	REDUCTEUR / GEARBOX
14	ANTI - STATIQUE / ANTI-STATIC
13	PALIER / BUSH
12	JOINT DE SIEGE / SEAT SPACER
11	SIEGE / SEAT
10	PRESSE ETOUPE DE SIEGE / SEAT ACTIVATOR
09	SUPPORT DE SIEGE / SEAT HOLDER
08	AXE INFERIEUR / TRUNNION
07	AXE DE COMMANDE / STEM
06	TOURNANT SPHERIQUE / BALL
05	BRIDE D'AXE INFERIEUR / TRUNNION FLANGE
04	CHAPEAU / BONNET
03	EMBOUT / BODY CONNECTOR
02	EMBOUT / BODY CONNECTOR
01	CORPS / BODY
REP	DESIGNATION

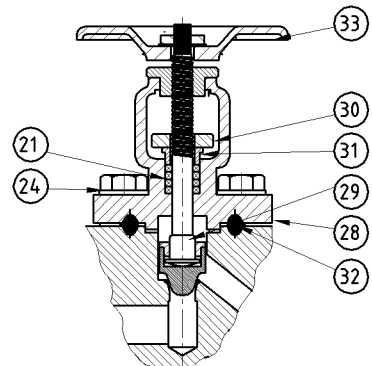

BLEED NEEDLE VALVE DETAIL

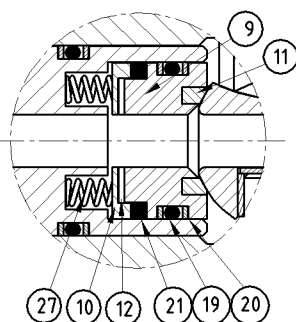

SEAT DETAILS

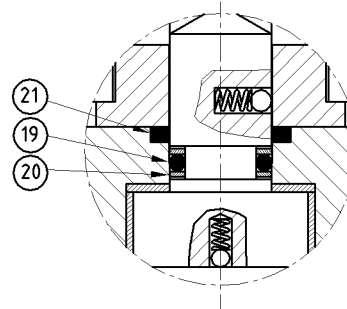

STEM DETAILS

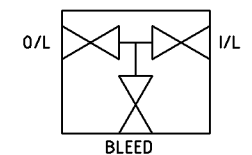

CS 3422
112,114 avenue de Vendôme
41034 BLOIS Cedex
FRANCE

DBB ARBRE TRUNNION BALL DBB

Sie 150 - 300 - 600 - 800 - 900 - 1500 - 2500
Class 150 - 300 - 600 - 800 - 900 - 1500 - 2500
BW NPT SW HUB BRIDE / FLANGE FF RF RT J