

CHAPEAU BOULONNE / BOLTED BONNET
JOINT RTJ / RING JOINT GASKET

Matériel conforme à NF M87.412 - BS5352 - API602
Matériel in acc. with BS 5352 - NF M87.412 - API 602

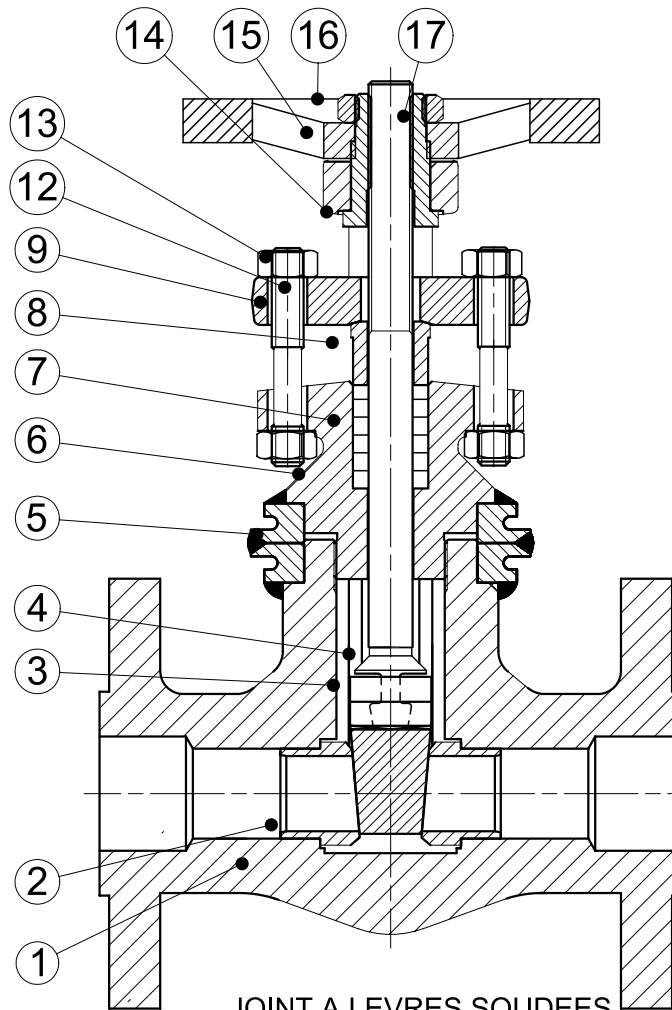

CS 3422
112,114 avenue de Vendôme
41034 BLOIS Cedex
FRANCE



JOINT A LEVRES SOUDEES
SEALED LIPS JOINT TYPE

Rep.	DESIGNATION
1	CORPS/BODY
2	SIEGE/SEAT
3	OPERCULE/WEDGE
4	TIGE/STEM
5	JOINT DE CHAPEAU/BONNET GASKET
6	CHAPEAU/BONNET
7	GARNITURE D'ETANCHEITE/PACKING
8	FOULOIR/GLAND
9	BRIDE DE FOULOIR/GLAND FLANGE
12	TIRANT/GLAND FLANGE STUD
13	ECROU DE TIRANT/GLAND FLANGE NUT
14	DOUILLE/BUSHING
15	VOLANT/HANDWHEEL
16	ECROU DE VOLANT/HANDWHEEL NUT
17	PLAQUE D'IDENTIFICATION/NAME PLATE
18	VIS DE CHAPEAU/BONNET SCREW

DISPONIBLE VERSION / AVAILABLE WITH
BUTT WELD END SUIVANT/ acc. to ANSI B16-25
SOCKET WELD END SUIVANT/ acc. to ANSI B16-11
NPT SUIVANT/ acc. to ANSI B1.20.1

ROBINET VANNE FORGE A BRIDES
FLANGED FORGED GATE VALVE
Sie / Class 150 - 300 - 600 - 900 - 1500 - 2500
PN 10 - 16 - 25 - 40 - 65 - 100 - 160

CHAPEAU BOULONNE - CHAPEAU SOUDE / SIEGE SERTI
BOLTED BONNET - WELDED BONNET / CRIMPED SEAT