

General Presentation

Company & Products

ICARUS

.ICARUS

innovative valve & piping solutions

A COMPREHENSIVE RANGE OF PRODUCTS AT YOUR SERVICE

GENERAL

VALVES

SUBSEA &
SPECIAL PIECES

PIPING & FITTINGS

SERVICES

COMPANY
PROFILE

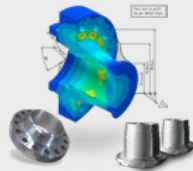

TEST RANGE
QUALITY ASSURANCE
PACKAGE
PROJECT MANAGEMENT
...

PRODUCTION

TRADING

European Manufacturer

a European origin

a global presence

Plants



.ICARUS

Pipe & fitting supplier(full package)
Valves, Subsea & special pieces manufacturer

Employees: 64

Engineering: 6
Quality: 9
Workshop: 7

Total surface:
34,500 m²

Covered surface:
8,300 m²

Parc Industriel des Hauts Sarts, Zone 3
Rue des Alouettes, 100 - 4041 Herstal
Belgique



SAGCAP

Valve manufacturer dedicated mainly to the oil & gas sector

Employees: 55

Engineering: 5
Quality: 6
Workshop: 27

Total surface:
40,000 m²

Covered surface:
9,000 m²

112, Avenue de Vendôme
41034 Blois
France



COYARD

Valve manufacturer specialized in the marine & energy sectors

Employees: 66

Engineering: 6
Quality: 4
Workshop: 39

Total surface:
10,800 m²

Covered surface:
5,300 m²

1, Rue de la nouette
Zone Industrielle d'Angers-Beaucouzé
49072 Beaucouzé Cedex
France

Activities

- Production of valves, flanges, and forged parts
- Supply of complete packages of piping and fittings



Valves

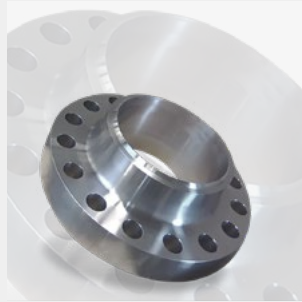

Compact and subsea flanges



Forged parts for subsea applications



Piping and fittings

Main Markets



Oil & Gas



Petrochemical industry



Energy

Clients

End-users



(oil & gas companies, (petro-)chemical industry, ...)

Engineering companies



Engineering companies

Equipment manufacturers



(industrial piping, boilerwork, industrial furnaces, ...)

COMMERCIAL POSITION

VALVES

Ø : 1/4" to 30"

Dual plate check valves	Wafer, double flanged, hub & BW ends
Other check valves	Tilting, disc, swing, piston
Double block & bleed	Ball x Ball (floating or T-M), Gate x Gate, Globe x Globe Various according to requirements
Ball valves	Floating Trunion-mounted
Gate & globe valves	Gate valves, globe valves, through conduit gate

PIPING & FITTINGS

Ø : 1/4" to 102"

Pipes	Welded or seamless, all thicknesses
Flanges	Compact, WN/SW/slip on & Blind standards, Long welding neck, orifice, anchor, swivel
Forged fittings	Elbows, tees, caps, couplings, plugs, nipples, o-lets
BW fittings	Elbows, tees, lateral & barred tees, reducers, caps
Flexibles	Flexible or metallic, hydraulic fittings
Bolting	Bolts, nuts, washers, screws, studs
Gaskets	API ring joints, anti-vibration, elastomer seals, engineering plastics, expansion joints, o-rings, hydraulic seals, spiral wound gasket
Clamps & hubs	Clamps connectors, hubs, API clamps

SUBSEA & SPECIAL PIECES

Ø : 1/4" to 36"

Offshore & subsea products	Compact flanges NORSOK L-005 or tailor made (swivel, integral,...), buckle arrestors, anchor pipes, hanger flanges, tees et barred tees, wyes, API6A/B – ASME B16.5 flanges, ... API 5L gr.X60-X65 linepipes end bends (incl. cladded/uncladded)
----------------------------	---

SERVICES

ENGINEERING	
Calculation	Structural resistance, tightness, CFD
Design	3D modelling & 2D design drawings
QUALITY	
Non-destructive tests	High pressure gas, magnetic, dye penetrant, PMI, ferrite, hardness, ultrasonic, pig test, fugitive emissions, cryogenic
Destructive tests	Sub-contracted according to requirements

References

We are supplier of clients such as:

- Total E&P
- Petronas
- Air Liquide
- Gazprom
- Navantia
- Total Raffinage
- Storengy
- General Electric
- Lukoil
- Chevron
- Exxon Mobil
- EDF
- Dubai Petroleum
- KNPC
- Aramco
- Technip
- BP
- McDermott
- Equinor
- Fluxys
- Saipem
- Eni
- NOC (North Oil Company)
- ADNOC
- QatarGas

Integrated quality management

handling company organization & management, product quality, health & security



ISO 9001
QUALITY MANAGEMENT SYSTEMS



ISO 14001
ENVIRONMENTAL MANAGEMENT SYSTEMS



ISO 45001
HEALTH & SAFETY MANAGEMENT SYSTEMS

Other Certifications

PED

2014/68/EU

PED 2014 / 68 / EU
PRESSURE EQUIPMENT DIRECTIVE

EAC

CUTR (RUSSIA)
CUSTOM UNION TECHNICAL REGULATIONS

CE

EUROPEAN CONFORMITY
EC DIRECTIVES FOR RELATED PRODUCTS

Key Technical Skills

- Welding Engineers (I.W.E.)
- Safety Officers
- Environmental Experts
- Quality Engineers

- Frosio III certified agent
- Cofrend II certified agents
- ACQPA level II and anticorrosive painting certified agent

	CLASS 150	CLASS 300	CLASS 600	CLASS 900	CLASS 1500	CLASS 2500	API 6A 3,000	API 6A 5,000	API 6A 10,000	
CHECK VALVES										
Dual plate Check	2" - 30"		2" - 24"			1 13/16" - 11"				
Disc Check	1" - 8"			-						
Other Check	Tailor made check valves upon request									
ON/OFF BALL VALVES										
Floating Ball & DBB	1/2" - 10"	1/2" - 8"	1/2" - 6"	1/2" - 2"	1/2" - 1"	-				
Trunnion Ball & DBB	1/2" - 24"			1/2" - 16"	1/2" - 12"	1 13/16" - 7 1/16"				
THROUGH CONDUIT GATE										
Slab gate	2" - 24"			1" - 24"	1" - 24"	1 13/16" - 7 1/16"				
Double expanding gate										
CASTING										
Gate		2" - 18"	2" - 14"							
Globe	2" - 24"	2" - 14"	2" - 10"	2" - 10"	2" - 8"	-				
Check (Swing)										
FORGINGS										
Gate							1 13/16" - 4 1/16"			
Globe				1/2" - 2"						
Check (Swing, Piston and Ball)										



Applications	Oil & Gas - Nuclear - Cryogenic - Oxygen Service - ...
Specific Features	3-Way Ball - Welded Design - Wafer Swing Check - Bellow sealed - ... Actuated as per request
Material	TOP QUALITY MATERIAL SOURCING – EUROPEAN ORIGIN ASTM – PED – NORSOK M630 – CUSTOMER SPECIFICATION Main: Carbon Steel (with cladding) / Stainless Steel / Duplex / Nickel Alloys Others: Cupro Aluminium / Titanium / ...

OUR STRENGTHS

- Deadline flexibility & responsiveness
- Valves for use under extreme conditions:
 - Low and high temperatures
 - Corrosive and abrasive products
 - High pressures
- Custom solutions

- Standards-compliant valve production
- Non-standard valve production
- Machined from bars, castings or forgings
- Specific and particular grades
- Engineering department allows management of specific requirements (Size constraint, pressure, corrosion, temperature, etc.)



ZERO GAS LEAKAGE DESIGNED & TESTED PRODUCTS

We are able to provide special designed valves, manufactured with proven practice. The precision and expertise of our work allow us to deliver gas valves that have been tested with zero leakage results during high pressure gas tests.



FIRE SAFE DESIGNED & TESTED PRODUCTS

Our products are Fire-Safe Certified according to ISO 10497, API 607, API 6FA, API 6FD and BS 6755. These certifications ensure our Dual Plate check valves strictly meet the performance requirements once they are facing fire conditions.



CRYOGENIC DESIGNED & TESTED PRODUCTS

Our technical knowledge and expertise at your service for cryogenic applications: we are equipped to perform low temperature to cryogenic pressure tests with our test benches according to BS6364 or specific customer requirements.



Sizes	from 2" to 30"
Pressure Ratings	ANSI: 150 to 2500 – API: 2,000 to 10,000
Material	Carbon Steel / Stainless Steel / Duplex Steel / Aluminium Bronze / High Nickel Alloys / Titanium... Forged or cast construction
Seats	Metal to metal (BARE, STELLITE®, ULTIMET®, HVOF TCC) / Soft seat (PTFE, RPTFE, HNBR, VITON®...)
End Connections	Wafer / Solid lug / Flanged / Buttweld / Hub ends

Note: This table describes the typical range of products. Other sizes or configurations are available on demand.

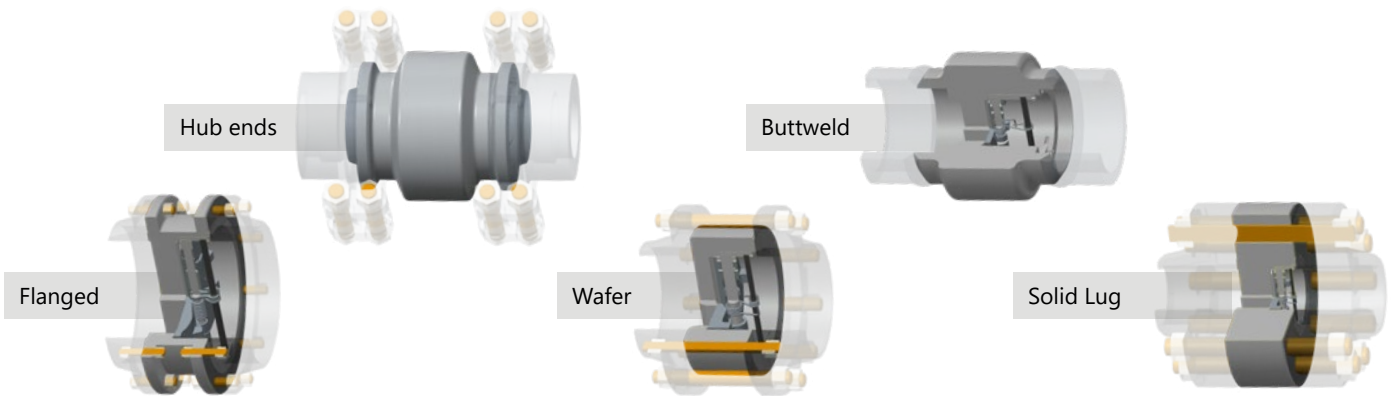

DESIGN

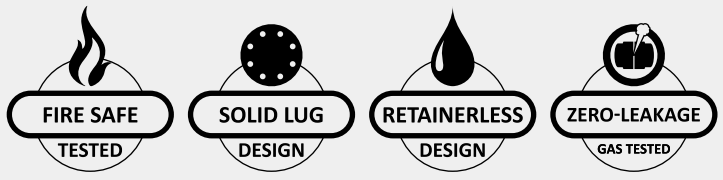
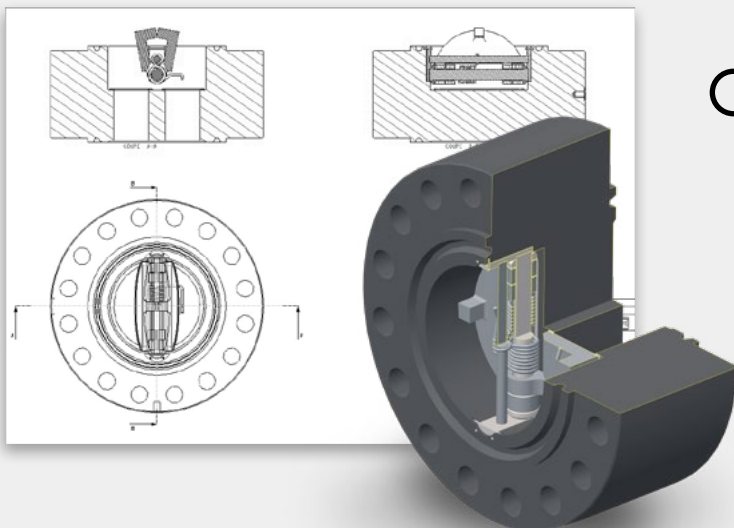

According to:

- API 594 ■ API 6D ■ API 6FD
- Customer specifications
- API & ISO Fire Safe certifications

FEA Analysis

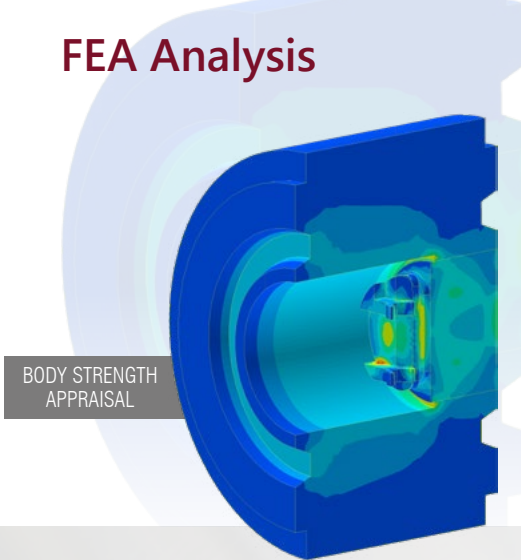
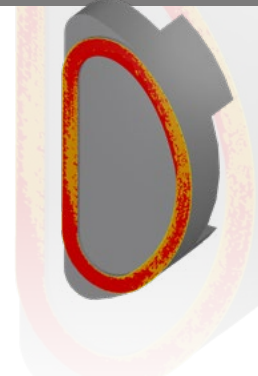
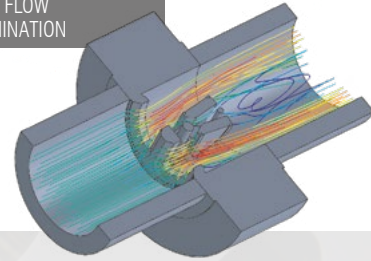

PLATE TO BODY SEATING AREA
TIGHTNESS VERIFICATION



CFD Analysis

PRESSURE DROP & FLOW
COEFFICIENT DETERMINATION



Inhouse production

- Castings and forgings coming from top quality european suppliers
- Inhouse machinery, assembly & testing (hydro / gas ...)
- Low/high pressure gas tested according to API598 & ISO5208
- Inhouse quality controls : MPE / DPE / Visual / Dimensional ...

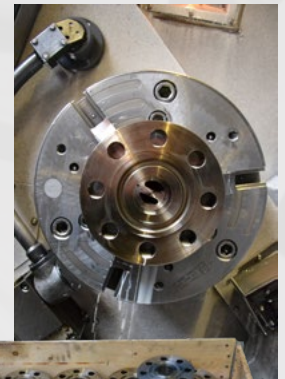
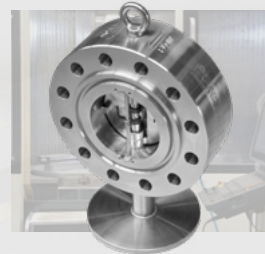

SOME REFERENCES

Application	DESCRIPTION
Ras Laffan, Qatar	8" 150#, A182, F316, Cryogenic
Offshore, Qatar	2"-16" 150-2500# LF2, F316, Al-Br, F44 (Frame Agreement Contract)
FLNG, Mozambique	2"-24" 150-1500# F316, Cryogenic
Gas Plant, Qatar	10" 150# Al-Br
Oxygen Pipeline, Belgium	12" 600# F316, Oxygen Service
Karsto, Norway	12" 150# Titanium
NASR Field, U.A.E.	2"-4" 300# CS,SS
Yamal, Russia	3"-30" 150-900# LF2, F316, Cryogenic
Martin Linge, Norway	2"-10" 150-600# F316, Duplex
Offshore, Congo	14" 300# LF2
Golfinho, Brasil	2-12" 150-2500# LF2, F316, F55
Pre-Khuff, U.A.E.	2"-6" 2500# Inconel® 625
Erha North, Nigeria	2"-12" 1500-2500# LF2
Amur, Russia	2"-3" 300# Inconel® 625

Design



55x Double Block & Bleed Valve
2" API 10,000 in A182 F55

According to:

- API 6A (PSL3G)
- API 6D
- Customer specifications
- Fire Safe as per API 607 / ISO 10497
- FET as per ISO 15848-1 / -2

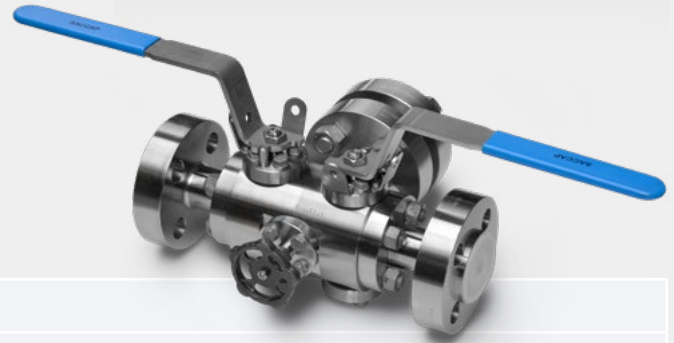

Type	Trunnion Mounted or Floating
Sizes	from 1/2" to 24"
Pressure Ratings	ANSI : 150 to 2500 – API : 3,000 to 10,000
Material	Carbon Steel / Carbon Steel + weld overlay (stainless steel, Nickel alloy) / Stainless Steel / Duplex Steel / Aluminum Bronze / High Nickel Alloys / Titanium ... Forged construction
Seats	Metal to metal (HVOF TCC, HVOF CrCC) / Soft seat (PTFE, RPTFE, PEEK, DEVLON® ...) Single piston effect/ Double piston effect
End Connections	All connections available (including custom made arrangement)to: Flanged / Hub ends / Butt weld / Cartridge ...



Trunnion Mounted Ball Valve
2" 1/16 to 3" 1/8 API 5,000 Inconel 625 or CS/SS
Destination: Qatar (Offshore)

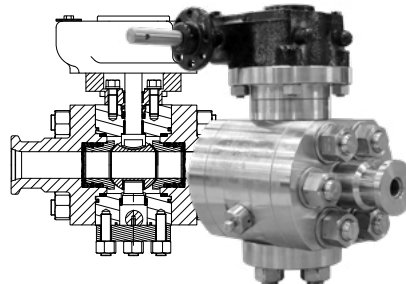

Trunnion Mounted Ball Valve
3/4" Ball
Destination: Norway

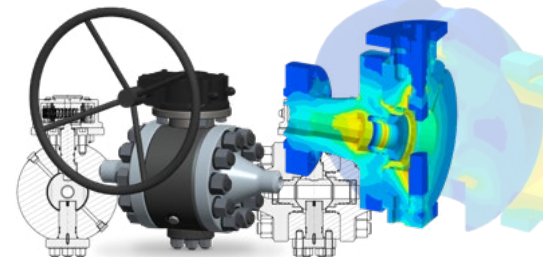

Trunnion Mounted Ball Valve
1" 13/16 to 2" 1/16 API 10,000 Gr60K
Destination: Indonesia

DBBS FOR INSTRUMENTATION, INJECTION,...



Double Block & Bleed valve
1/2" 2500# F51

Destination: Norway

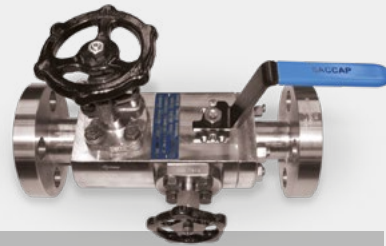

Double Block & Bleed valve
Globe / Needle / Ball valve

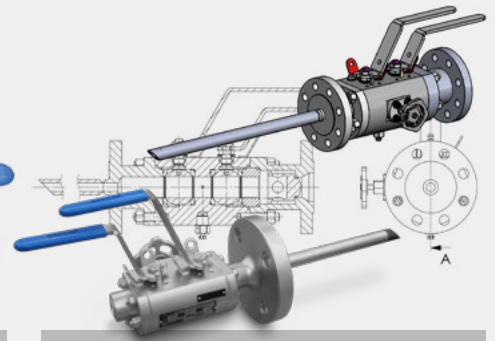

Double Block & Bleed valve
with injection quill

SPECIAL DESIGN BALL VALVES & DBBs



Cryogenic ball valve
8" 2500# 316

Destination: Algeria



Double 3 ways valve
2" 4500# Carbon Steel

Destination: Norway



Ball valve with stem extension (for insulation)
2" 300# F321 (-46°C to 160°C)

Destination: Norway

LARGE SIZE BALL VALVES & DBBs



Trunnion Mounted Ball Valve
12" 1500# Carbon Steel

Application: Offshore



Trunnion Mounted Ball Valve
20" 1500# Carbon Steel

Destination : Qatar (Offshore)



Double Block & Bleed Valve
12" / 16" / 24" 1500# Carbon Steel – 24" 1500

Destination: UAE (Offshore)

FET TESTED
ISO 15848-1 CLASS B C01

PRODUCT RANGE

	CLASS 150	CLASS 300	CLASS 600	CLASS 900
Disc Check	1" - 8"			

Options

Cryogenic - Oxygen Service - High Temperature - Special / Low Flow Conditions...

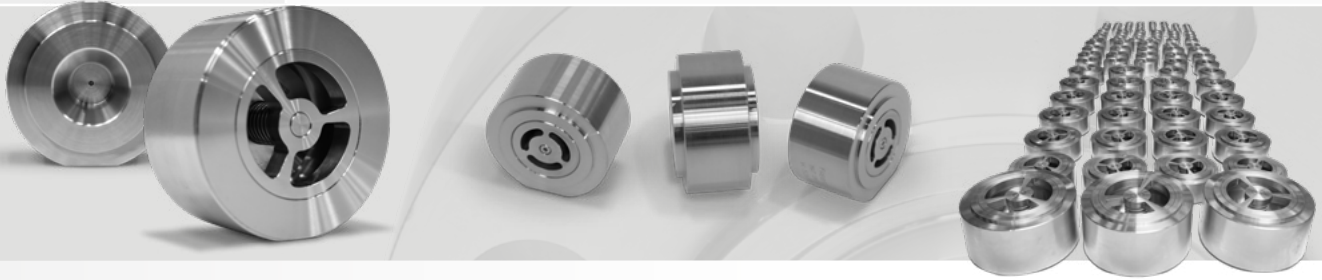

INHOUSE PRODUCTION

- Inhouse machining, assembly & testing (hydro / gas...)
- Low/high pressure gas testing according to API 598, API 6A & ISO 5208
- Inhouse quality control : MPE / DPE / Visual / Dimensional...
- Castings and forgings coming from top quality European partners
- Stock of trim components in the most common grades

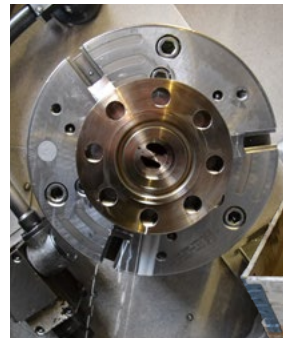
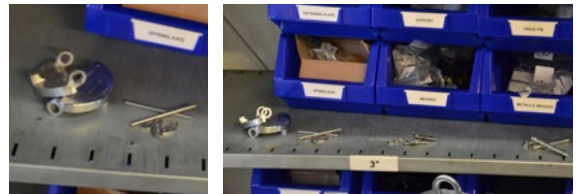

Cryogenic valves

Disc Plate check valves are fit for cryogenic applications thanks to specific design and lapping based on years of experience in LNG and FLNG projects. Low temperature pressure tests are performed in our test benches according to BS6364, ISO 28921-1, EN 12567 or specific project requirements.

On the picture:
a 30" Dual Plate check valve
after successful testing at -196°C





Sizes	from 1" to 8"
Pressure Ratings	ANSI: 150 to 900
Material	Carbon Steel / Stainless Steel / Duplex Steel / Aluminium Bronze / High Nickel Alloys / Titanium... Forged or cast construction
Seats	Metal to metal (option: hardfacing)
End Connections	Wafer / Solid lug

Note: This table describes the typical range of products. Other sizes or configurations are available on demand.

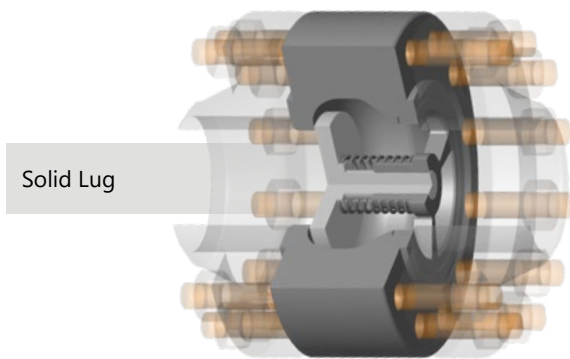
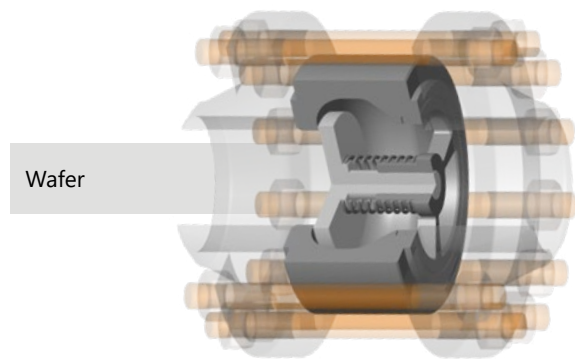

DESIGN

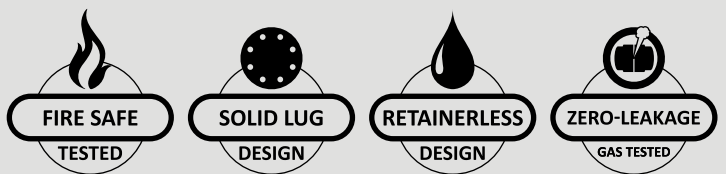
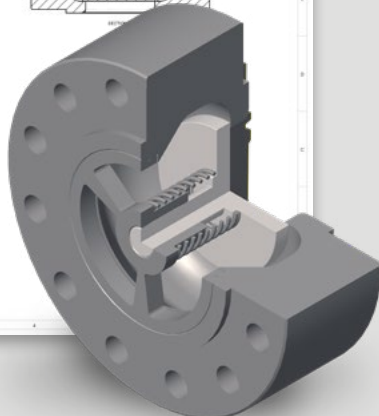
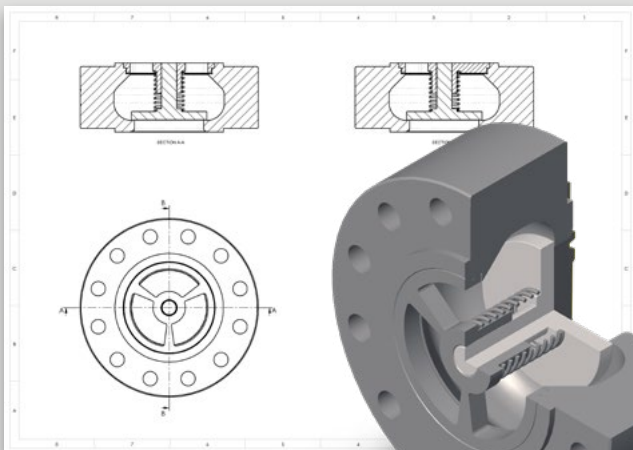

According to:

- API 594 ■ API 6D ■ API 6FD
- EN 16767
- Customer specifications

SPECIFICATIONS

- Non slam type
- With counterweights
- With rotational damping system
- Custom face to face
- Machined from forged material

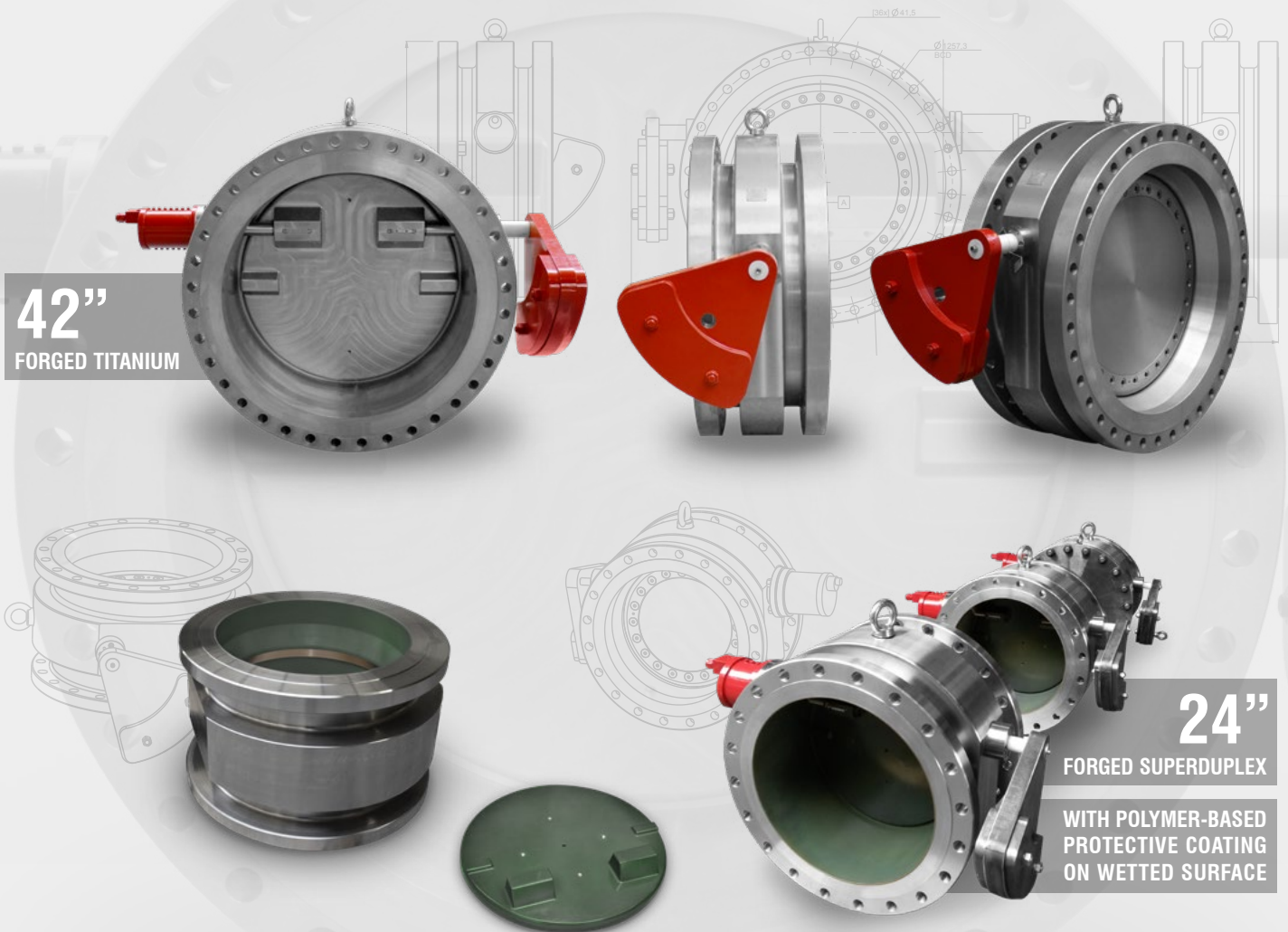

42"
FORGED TITANIUM

24"
FORGED SUPERDUPLEX

WITH POLYMER-BASED
PROTECTIVE COATING
ON WETTED SURFACE

PROJECT DETAILS

- Project: Kårstø Gas processing facilities, Norway
- Scope:
 - 2 check valve 42" 150Lbs RF in Titanium B381 F2
 - 3 check valves 24" 150Lbs RF in Super Duplex A182 F55

THROUGH CONDUIT GATE VALVE

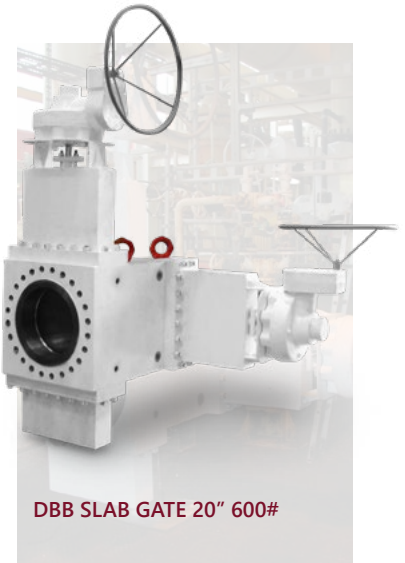
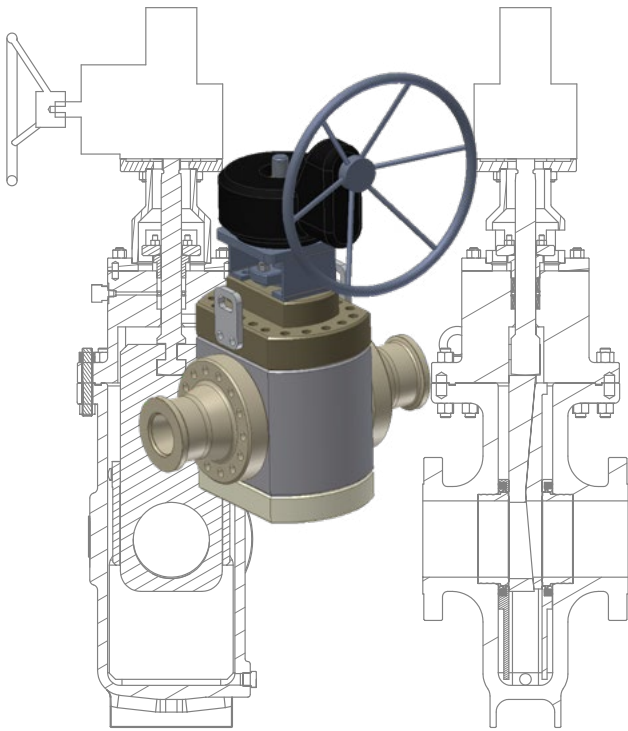

Sizes	from 2" to 24"
Pressure Ratings	ANSI : 150 to 2500 – API : 2,000 to 10,000
Material	Carbon Steel / Stainless Steel / Duplex Steel / Aluminum Bronze / High Nickel Alloys / Titanium ... Forged or cast construction
Seats	Metal seated – Soft seated – Metal & Primary soft seated
End Connections	Flanged / Buttweld / Hub ends
Testing	Low/high pressure gas tested according to API598 & ISO5208

Some references

PROJECT	DESTINATION	DESCRIPTION
Martin Linge	North Sea (NCS)	10" & 2" #1500 T.C. D.E. Gate CS / F51
Judy/Joanne Fields	North Sea (UKCS)	2" #300 T.C. Gate Slab Gate (Cryogenic service) CS / 316
Shah Deniz	Baku	3" #300 T.C. D.E. Gate CS / 316
Kittiwake platform	North Sea (UKCS)	8" 10000 PSI T.C. Slab Gate (compact flanged) AISI 4130
PG2 Electric plant	Gabon	6" #300 T.C. D.E. Gate A216 WCB / 316
Shah Deniz	Caspian Sea	12" #300 / 14" #600 T.C. D.E. Gate Flanged RF 316 / 316 + Stellite® 6

Custom products & solutions

- Experienced engineering team
- Most advanced modelling & simulation software
 - FEA :
 - Samcef Field
 - Siemens NX
 - Ansys
 - CAD :
 - Solidworks
 - Autodesk Autocad
 - CAM :
 - Mastercam
 - CFD:
 - Solidworks Flow Simulation



Calculation notes based on standards / rules of good practice

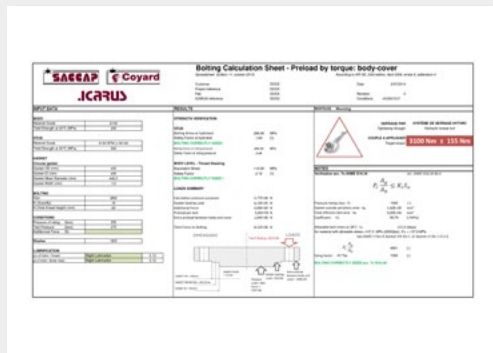

Bolting calculation:

- Tightening torque
- Reaction forces between parts
- Working coefficient (safety)

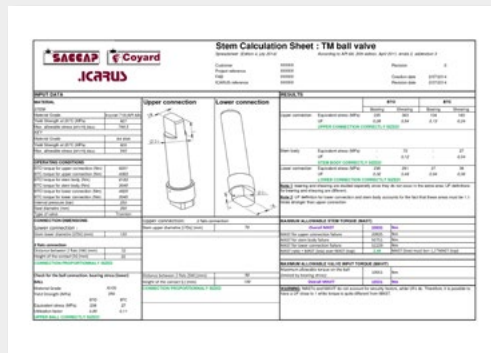

Stem dimensioning:

- Allowance for different shapes of stem-ends
- Working coefficient
- Maximum resistance of stem

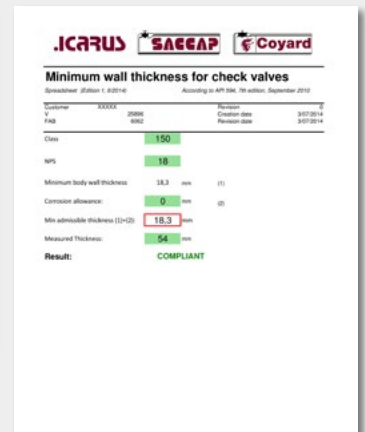

Wall thickness calculation for check valves

Finite Element Analysis :

- Ball/seat sealing
- Body resistance assessment
- Distortion verification (in order to ensure sealing)

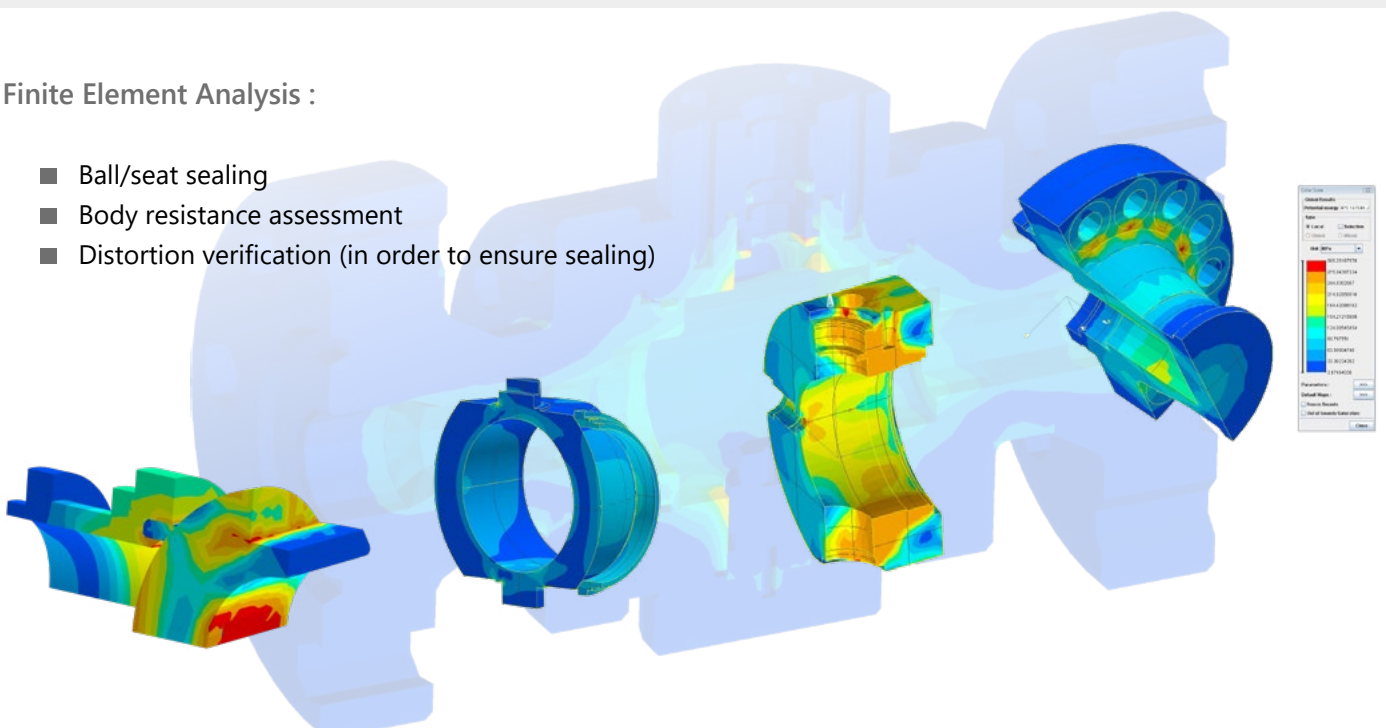

MORE THAN A PRODUCT

Icarus owns a dedicated team using integrated management (Quality / Engineering / Production), following the ISO 9001 / 14001 (Environment) & 45001(Health & Safety) and API Q1 requirements to ensure the highest level of quality management.

Each process is subject to a risk assessment in order to maintain this very same quality management level.



Products

<p>Pipes</p> <p>Seamless & Welded Finned / Studed</p> <p>All dimensions All wall thicknesses</p>	<p>BW Fittings</p> <ul style="list-style-type: none"> ▪ Elbows ▪ Tees ▪ Lateral & Barred Tees ▪ Reducers ▪ Caps 	<p>Forged Fittings</p> <ul style="list-style-type: none"> ▪ Elbows ▪ Tees ▪ Caps ▪ Couplings ▪ Plugs ▪ Union ▪ Crosses ▪ O-lets 	<p>Clamps & Hubs</p> <ul style="list-style-type: none"> ▪ Clamps connectors ▪ Hubs ▪ API Clamps
<p>Flanges</p> <ul style="list-style-type: none"> ▪ Compact flanges ▪ Standard flanges ▪ Long welding neck ▪ Orifice ▪ Anchor ▪ Swivel ▪ Fully designed & calculated flanges 	<p>Bolting</p> <ul style="list-style-type: none"> ▪ Bolts ▪ Nuts ▪ Washers ▪ Screws ▪ Studs 	<p>Gaskets</p> <ul style="list-style-type: none"> ▪ API ring joints ▪ Anti vibration ▪ Elastomer seals ▪ Engineering plastics ▪ Expansion joints ▪ O-rings ▪ Hydraulic seals ▪ Spiral wound gaskets 	

Material grades

<p>Stainless steel Corrosion resistance</p> <ul style="list-style-type: none"> ▪ 316 Mo+ ▪ 317L ▪ Alloy 28 ▪ Alloy 20 ▪ 904L ▪ 19.25 HMo ▪ 254 SMO® ▪ 310L 	<p>Alloy & Stainless steel</p> <ul style="list-style-type: none"> ▪ P11 ▪ P22 ▪ P5 ▪ P9, P91 ▪ 316L ▪ 304L ▪ 304H ▪ 321H ▪ 347H ▪ 310S 	<p>Austenitic-ferritic steel</p> <p><u>Duplex</u> : UNS S31803 / S32205</p> <p><u>Super Duplex</u> : UNS S32750 / S32760</p> <p>Nickel & Nickel alloy</p> <p>Alloy 600, 601, 625, 825, 400, 200/201, C276, C22, 800, 800H, 800HT</p>	<p>Carbon steel</p> <ul style="list-style-type: none"> ▪ A106 Gr B ▪ A105 ▪ A234WPB ▪ P265 GH <p><u>Low temperature</u> :</p> <ul style="list-style-type: none"> ▪ LF2, A333 Gr 6 ▪ LF3, A333 Gr 3 <p><u>High yield strength</u> : API 5L X52-60-65-80</p>
---	---	--	---

... this is a non-exhaustive list, Do not hesitate to contact us for other needs.

ICARUS MATERIAL COMPARISON

EUROPEAN STANDARD	SAE	UNS	ASTM	ASME
AUSTENITIC, FERRITIC & FERRITIC-AUSTENITIC STAINLESS STEEL				
X 1 CrNi18.9	316	S 31600	A 312	SA 312
X 1 CrNiMo18.2	316L	S 31603	A 312L	SA 312L
X 1 CrNi18.9	316	S 31600	A 312	SA 312
X 1 CrNiMo18.2	316L	S 31603	A 312L	SA 312L
X 1 CrNi18.9	316	S 31600	A 312	SA 312
X 1 CrNiMo18.2	316L	S 31603	A 312L	SA 312L

PDF version available for download at www.icarus-be.com

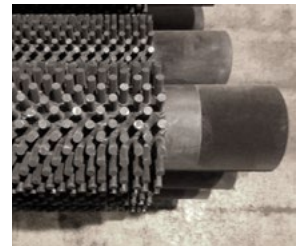

Extruded Manifolds
Material : Alloy 800 HT

Extruded Manifolds
Material : Alloy 800 HT

Induction Bends for topside application & riser systems

Icarus works alongside with world leading manufacturer of pipe bends to provide a wide range of bending solutions :

■ **High Flexibility**

- All types of material : starting from seamless or welded pipes in CS, Alloy Steel, SS, DSS, SDSS, Nickel Alloy and clad pipes with weld overlay method.
- Wide range of bend radius, angle and bend plane
- Close tolerances (optimum ID tolerances...)

■ **Several applications : sour service, low temperature, topsides, ...**

■ **Optimum Heat Treatment Process to meet the strict mechanical requirements**

- Stress relieving
- Normalizing
- Quenching & Tempering
- Solution Annealing

■ **Full compliance to International Standards and Specifications :**

- DNV (DNV-OS-F101, ...)
- TOTAL specifications (PVVs, PLR 231, ...)
- Chevron's specifications (PPL-SU-U737-D, ...)

...



22" 3D Bends
Material : API 5L GrB X65

8" 3D Bends
Material : Duplex UNS S31803

Contractor : HHI
Client : BP
Project : Clair Ridge

6" 3D Bends

Material : Duplex UNS S31803
Contractor : Subsea7
Client : Total
Project : Pazflor
Standards : DNV-OS-F101





42" 5D Bends

Dimension : ID 1068,4 mm x 54,5 mm
Material : API 5L X65 PSL2 (SAWL)
Contractor : DSME
Client : Chevron Australia
Project : Wheatstone Upstream Project

6" & 10" 5D Induction Riser Bends

Material : API 5L X60 QS PSL2
Contractor : DSME
Client : Chevron
Project : Mafumeira Sul Project



6" 5D Bends Pressure test

Material : API 5L X65 PSL2 (DNV 450)
Contractor : Technip France
Client : Tullow
Project : TEN Project
Standards : DNV-OS-F101

6", 8" & 10" 5D Bends

Material : API 5L X65 PSL2 (DNV 450)
Contractor : Technip France
Client : Tullow
Project : TEN Project
Standards : DNV-OS-F101



Our technical support at your service

We are at your disposal for:

- Studies undertaken according to your requirements
- Flanges and forged pieces
- Special parts

Compact flange vs. ASME flange

Main benefits of L-005 compact flange

- Much **lighter** (save up to 80% on weight)
- **Smaller dimensions** (in both overall length and diameter)
- **More reliable** sealing : seal ring instead of gaskets
- Multiple sealing areas
- No corrosion/erosion on flange faces (gapless)
- No need to re-tighten bolts on a regular time scale

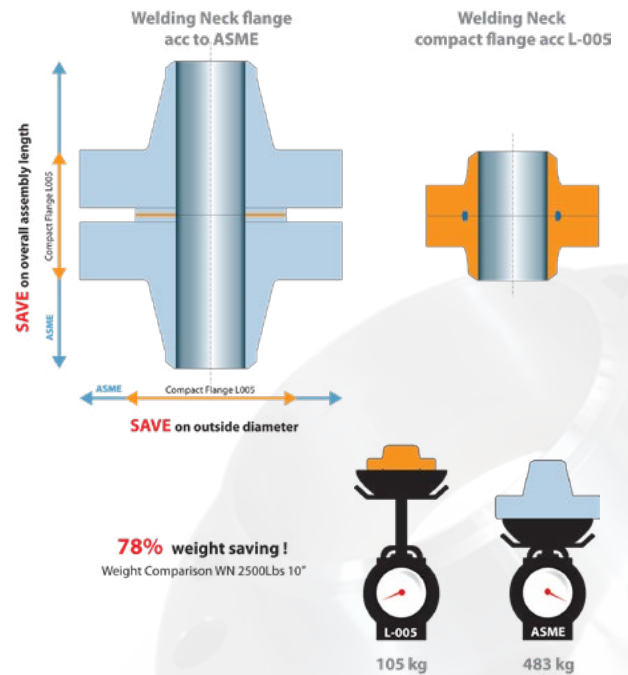

The Raised Face (RF) on an ASME flange is a weak point

- 1) Bending forces on the piping system will relax bolting on ASME flanges after a while so that re-tightening of the bolts is required. Which is not the case for compact flanges.
- 2) Gap between 2 ASME flanges (due to RF) can cause crevice corrosion or erosion.

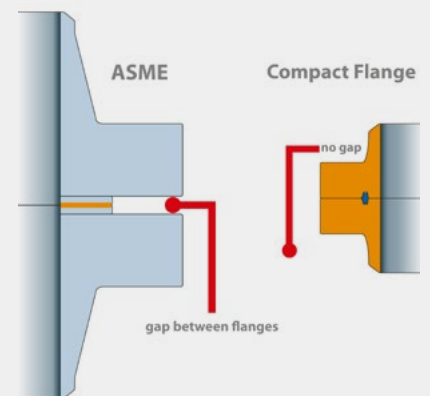

Special forgings

All sizes from ½" up to 24" (ext. Ø) and larger,
up to 36" on request
Maximum length up to 3500mm

High strength carbon steel, stainless steel forgings,
including duplex and super stainless steel, nickel
alloy, copper alloy and titanium alloy

- Buckle Arrestors
- Pipe Anchors
- Hanger Flanges
- Tees and barred tees
- Wyes
- Flanges API6A/B – MSS SP44 – ASME B16.5
- Compact flanges Norsok L005

Exemple of partnership

Partners forge masters working on our design and drawings :



- UK based forgemaster (Sheffield)
- Metal forgings from 1 kilo to 1200 kilos
(maximum outside diameter: 1050mm)
- Ring-rolling up to 1500mm

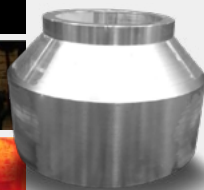
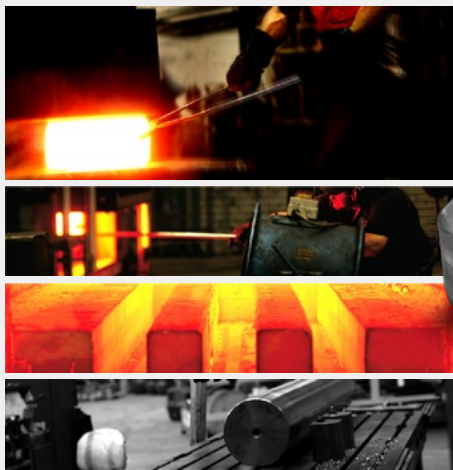

- Spain based forgemaster (Zestoa near Bilbao)
- Three free forgings presses, with a maximum
capacity of 5000 Tons
- Forgings and machining of parts up to 40 Tons
- Discs : maximum diameter is 3500 mm (40 000 kg)
Rings : maximum diameter is 4500 mm (10 000 kg)

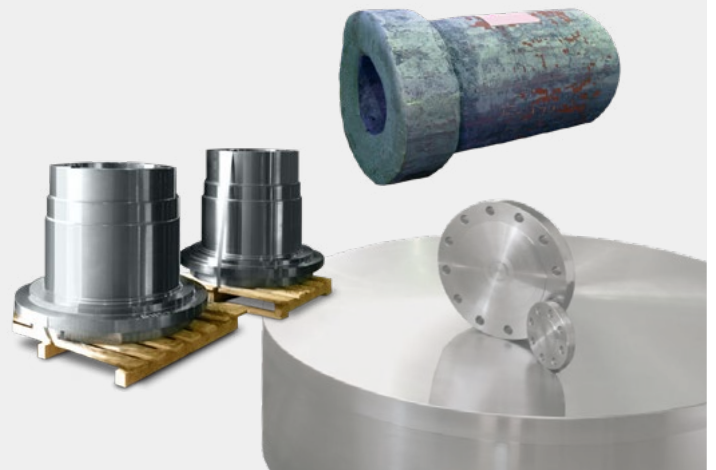

Custom products & solutions

- Experienced engineering team
- Most advanced modelling & simulation software

- FEA :
 - Samcef Field
 - Siemens NX
 - Ansys
- CAD :
 - Solidworks
 - Autodesk Autocad
- CAM :
 - Mastercam
- CFD:
 - Solidworks Flow Simulation

SAMTECH

PLM Software
SIEMENS NX

SOLIDWORKS

Autodesk

ANSYS

Mastercam

Our services

- Design and manufacture of custom products
- 3D modelling services
- FEA Analysis
- Calculations
- Reverse engineering services



FEA ANALYSIS



DETAILED CALCULATION NOTES

Design

Long welding neck self reinforced

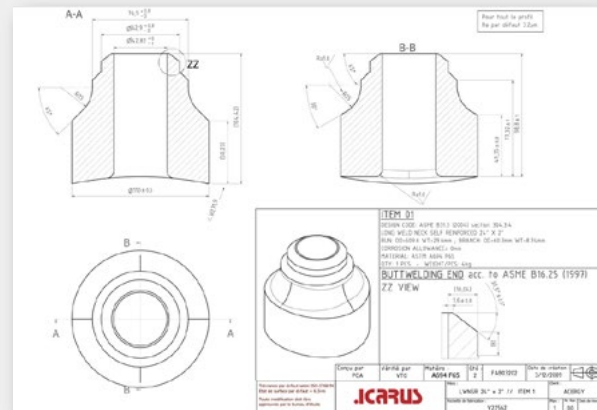
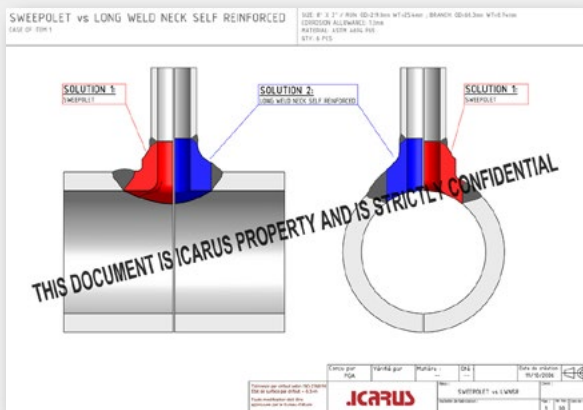

Wyes

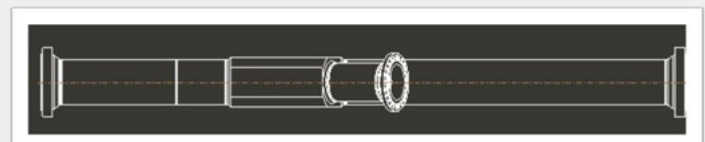
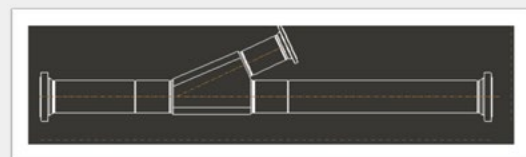
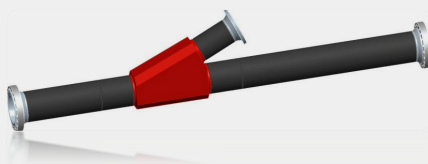

Calculation note

Compact Flange

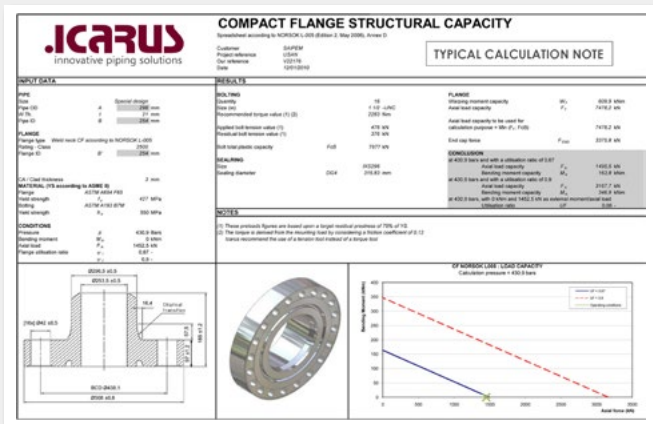

Welding Neck CF 11"
 Typical note for weldolet

Weldolet

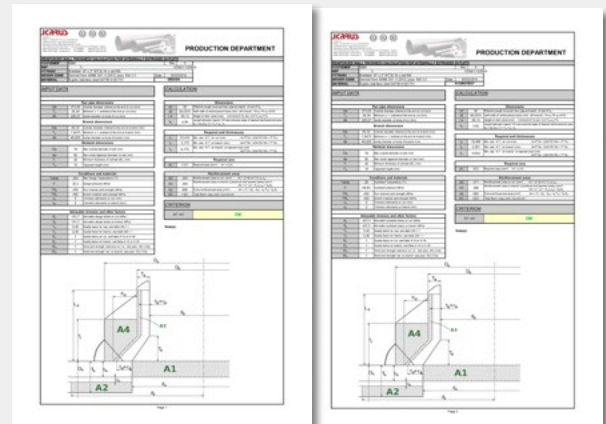

Weldolet 10" x 2"
 Typical note for weldolet

In-house FEA calculation

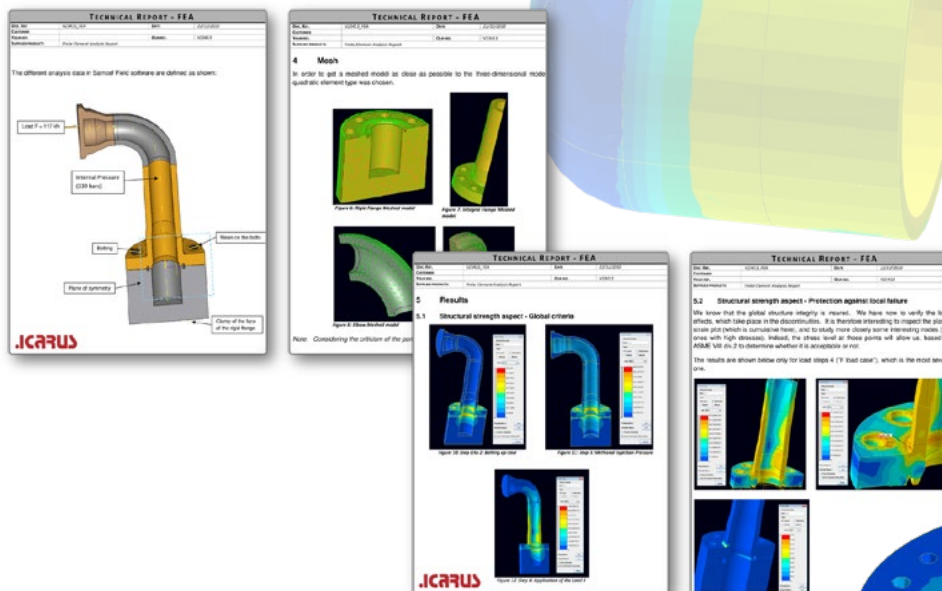

Supply of complete package

We are able to provide you a complete package of products for your project

- Standard or special valves
- Piping & fittings
- Special parts from Engineering (flanges, forgings, etc.)

Services provided

The entire range of supplied products is supported by an offer of complete services

- Quality assurance / Quality control
- Contract review
- Proven project management
- Following standards and specifications required by each project
- ITP management
- Third-party inspection
- Expediting
- Certificate management
- ...

Quality assurance



Dimensional analysis

Specific measurement tools

- FARO 3D measuring arm
- Wenzel 3D measuring table
- Someco Dynascan profile projector
- Coating thickness measurement tool
- Ultrasonic thickness measurement



Test range

Non-destructive tests

- Magnetic particle examination
- Dye Penetrant test
- PMI
- Feritscope®
- Hardness
- Ultrasonic test
- X-ray
- Pig gauge trial



Additional tests on demand

Simulation of extreme conditions

Specific service or environment

- High pressure (air / gas / water)
- Fugitive emission test (helium)
- Cryogenic test
- Fire test

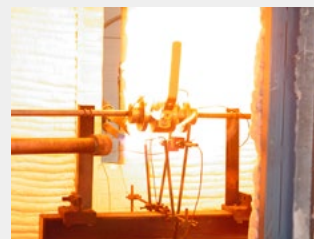

Pressure tests

Test capacities:

- Hydraulic up to 1200 bars
- Pneumatic up to 6 bars
- High pressure gas up to 1000 bars
- Cryogenic down to -196°C
- Leak detection test (with helium)

Test equipment:

- Presses
- Safety bunkers for pressure tests
- Cryogenic tanks

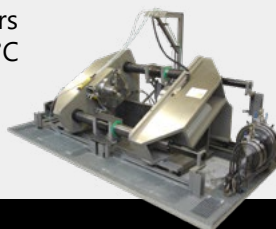

CRYOGENIC SETUP

DEDICATED EQUIPMENT & TECHNICAL CAPACITIES

In-house validation of cryogenic capabilities by testing @-196°C according to BS 6364, ISO 28921-1, EN 12567 or customer specification.

Tightness testing with Helium.

